

HD Conference Camera

User Manual

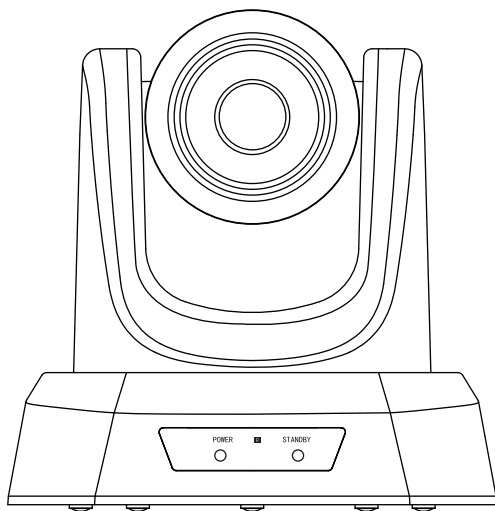

Version V5.09

Contents

Product Description-----	1
Packing List-----	3
Performance Characteristics-----	4
Remote Control Button Description -----	5
Camera Menu Set -----	6
Common Operation Instructions -----	8
Installation Instructions -----	11
Trouble Shooting -----	12
Maintenance Services -----	13
Warranty Card-----	14

1. Product Description

1.1 USB version

1.1.1 USB Interface Definition

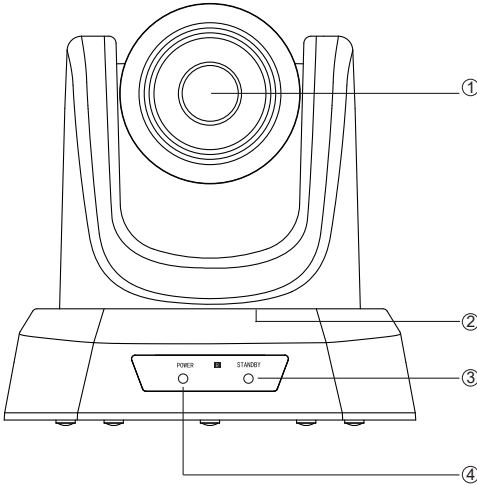

- ① Lens
- ② Pan&Tilt
- ③ Standby
- ④ Power indicator

1.1.2 USB Interface Diagram

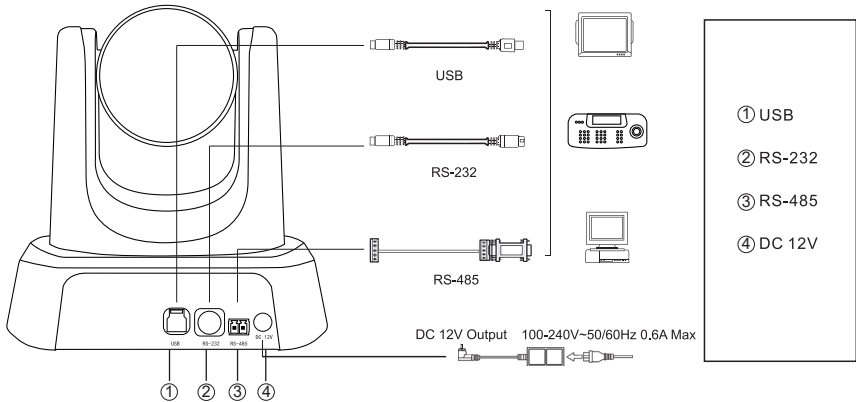

1.2 USB+HDMI+SDI version

1.2.1 USB+HDMI+SDI Interface Definition

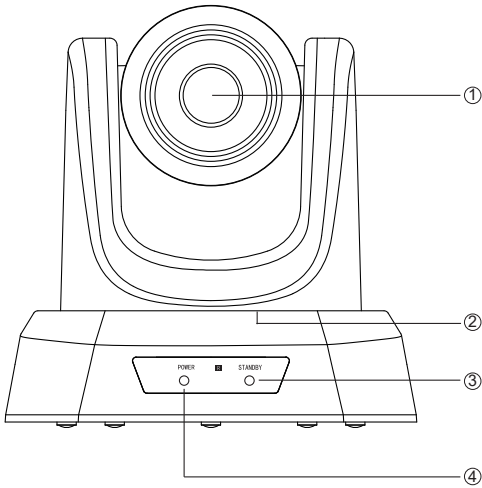

- ① Lens
- ② Pan&Tilt
- ③ Standby
- ④ Power indicator

1.2.2 USB+HDMI+SDI Interface Diagram

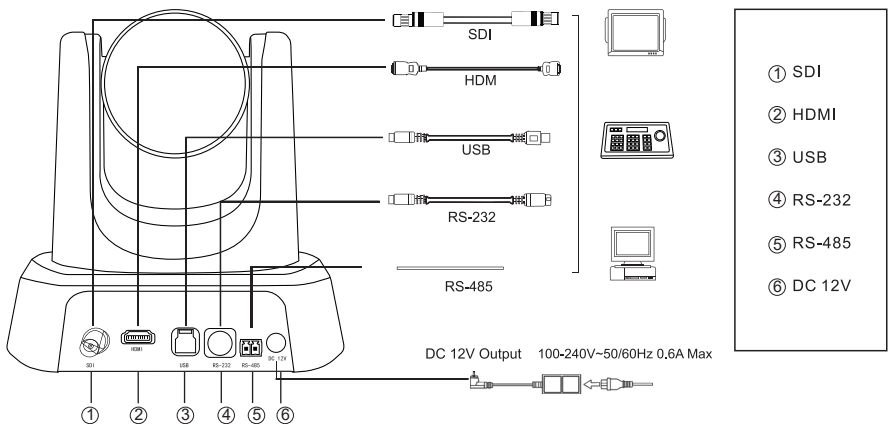

2. Packing List

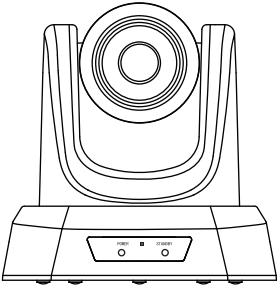

HD conference camera



DC 12V power supply



Ceiling mount

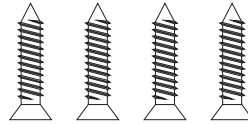

Mounting screws

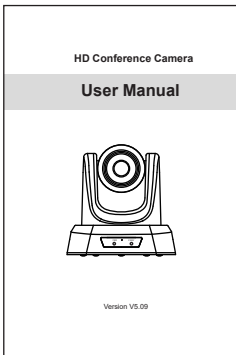

User manual

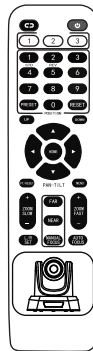

Remote control

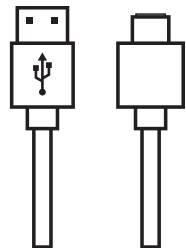

USB cable

3. Performance Characteristics

Model	NV4K	NV400	NV3U	NV10U	NV20U	NV10A	NV20A
Sensor	1/2.8"SONY CMOS	1/2.8" SUNNY UHD CMOS	1/2.9" CMOS				
Effective pixel	8.29 mega pixel		2.1 mega pixel			2.38 mega pixel	
Video signals	4K/30/25, 2K/30/25, 1080p/30/25	4K/30/25, 2K/30/25, 1080p/30/25	1080p/30/25, 720p/30/25	1080p/30/25, 720p/30/25	1080p/30/25, 720p/30/25	1080p/30/25, 1080i/60/50, 720p/60/50	1080p/30/25, 1080i/60/50, 720p/60/50
Zoom	fixed focus	10x optical zoom	3x optical zoom	10x optical zoom	20x optical zoom	10x optical zoom	20x optical zoom
Lens	f=2.2mm	f=4.34 -35.17mm	f=3.35 -10.05mm	f=5.0 -50.0mm	f=5.35 -107.0mm	f=5.0 -50.0mm	f=5.35 -107.0mm
Aperture	F1.8	F1.85-2.63	F1.6-F3.0	F1.8~2.1	F1.6-F2.7	F1.8~2.1	F1.6-F2.7
Horizontal angle	107°	68.8°(W) -8.8°(T)	99.6°(W) -30.6°(T)	54.8°(W) -5.8°(T)	55.4°(W) -3.55°(T)	68.8°(W) -8.8°(T)	58.6°(W) -3.6°(T)
Vertical angle	71°	39.5°(W) -5.1°(T)	53.0°(W) -17.2°(T)	41.2°(W) -4.38°(T)	31.6°(W) -2.00°(T)	39.5°(W) -5.1°(T)	54.7°(W) -3.3°(T)
Diagonal angle	116°	77.2°(W) -10.1°(T)	129.2°(W) -37.6°(T)	67.6°(W) -7.15°(T)	62.6°(W) -4.05°(T)	77.2°(W) -10.1°(T)	60.2°(W) -3.7°(T)
Video encoding format	MJPEG, YUV	H.264, H.265, MJPEG, YUV	H.264, MJPEG, YUV				
Video resolution	4K(3840*2160)etc		1080P (1920 *1080) etc				
Signal standard	NTSC/PAL						
Preset position	User can set up to 64 presets (IR remote 10 presets)						
Control terminal	RS-232, RS-485						
Shutter	1/30s~1/10000s, auto						
Baud rate	38400/9600bps						
Control protocol	VISCA, PELCO-D, PELCO-P(RS-232, RS-485)						
USB protocol	UVC1.1						
Minimal illumination	0.1Lux						
SNR	≥50dB						
Horizontal rotation	350° (±175°) 0.1°/s-100°/s						
Vertical rotation	90° (±45°) 0.1°/s-80°/s						
Power supply	DC 12V/2A						
Power consumption	12W						
Work temperature	0°~+50°						
Work humidity	0~95% RH						
Product size	181*184*174mm/257*220**198mm(before / after packing)						
Product weight	1.5kg/2.0kg(net / gross weight)						

4. Remote Control Button Description

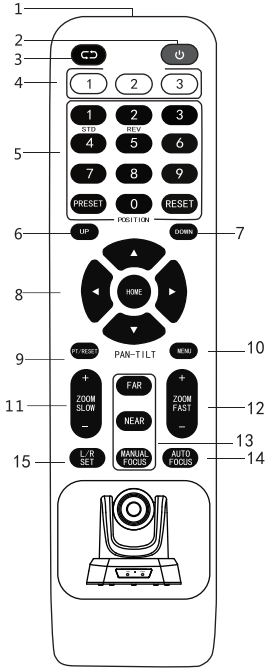

No	Name	Function
1	Launch Window	Remote Control Launch Window
2	Standby KEY	Enter into Standby mode by pressed it
3		The function of this key is reserved
4	Camera Select KEY	Select the camera need to control
5	Position	Preset position setup keys, include 【PRESET】 and 【RESET】
6	UP	Camera rotates horizontally in regular installed direction
7	DOWN	Camera rotates horizontally in reversed installed direction
8	PTZ Control KEY	PTZ move according to the arrow indicates. Press Home PTZ will back to the middle position
9	PT RESET KEY	Camera Pan/Tilt reset
10	MENU	Enter or exit OSD Menu after pressed it
11	ZOOM SLOW KEY	Zoom in + or out - slowly
12	ZOOM FAST KEY	Zoom in + or out - quickly
13	MANUAL FOCUS KEY	Manual far-end/near-end focus
14	AUTO FOCUS KEY	Auto far-end/near-end focus
15	L/R SETTING KEY	Support, press this key for 10 seconds

★Attentions for Remote Control

1. If the remote control doesn't work, please replace batteries.
2. If there is an object between the remote control and a specialized remote control sensor, the camera will not work. Please make sure the remote control is aimed at the sensor which is in front of the camera when controlling it.
3. Zoom fast, zoom slow, manual focus and autofocus keys are not applicable for fixed focus models.

5. Camera Menu Setup

When operating remote control, press **【MENU】** to enter main menu of the video camera.

5.1 Level I Menu - Main Menu

Main Menu	
Exposure	->
Color	->
Image	->
Information	->
Language	Chinese
Exit	Not Save

Language: Support Chinese/English

Exit

Save
Not Save
Default

5.2 Level II Menu-Exposure

Exposure	
Brightness	< 50 >
Flicker	< 50Hz>
Back	<-

Brightness: Adjust the brightness of the image.

Flicker: Support 50Hz/60Hz.

5.3 Level II Menu-Color

Color	
Contrast	< 50 >
Hue	< 50 >
Saturation	< 50 >
Sharpness	< 50 >
WB Mode	< Auto >
Color Temp	< 5600 >
Back	<-

Contract: Set image contrast Dynamically, Default 50, 0-100.

Hue: Set the relative brightness of the image, Default 50, 0-100.

Saturation: Set image color effect, Default 50, 0-100.

Sharpness: Set sharpness level, Default 50, 0-100.

Color Temp: Set color temperature, Default 5600, 1500-15000.

5.4 Level II Menu-Image

Image	
Flip	< on >
Mirror	< on >
Resolution	1080I 50
Back	<-

Flip: Enable/disable the picture up/down flip.

Mirror: Enable/disable the picture left/right flip.

Resolution: 1080I60/50, 1080P30/25, 720P60/50.

Notice: Resolution is just workable for multi-ports HD conference camera.

5.5 Level II Menu-Version

Version	
Model	HD Camera
Date	2.2.1.1 2021-06-19
Back	<-

Model: HD Camera

Version: 2.2.1.1

Date: 2021-06-19.

Notice: The version number here is just an example, the actual parameters shall prevail.

6. Common Operation Instructions

6.1 Camera Select

Refer to the dial-up at the bottom of the camera and choose camera address number that you want to control (1-3) .



6.2 Camera Direction Control



Turning up



Turning down



Turning left



Turning right



Turning to default



Note: Press the direction key when you need to adjust the angle. If you want to move the camera slowly, just click the direction key; If you want to move the camera fast at a large scale, just long-press the button.

6.3 Camera Focusing Mode Control

【AUTO FOCUS】 Switch the focus mode to AUTO

【MANUAL FOCUS】 Switch the focus mode to MANUAL

【FAR】 Far focus manually

【NEAR】 Near focus manually

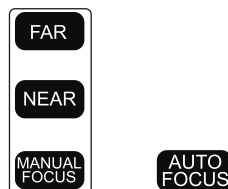

6.4 Camera Zoom Control

Press any one of the 4 **【ZOOM】** to make the zoom functioning. These 4 keys are not applicable for fixed focus cameras.



6.5 Preset Setup, Call, Cancel

(1) Reserve Preset: Press **【PRESET】**, then press one of the numbers(0-9) to reserve a preset that correspond to the NUMBER.

Note: you can setup 10 presets at most by the remote control.

(2) Call Preset: Press the NUMBER (0-9) directly to call the reserved preset.

Note: It won't work if there's no preset reserved in the corresponded number.

(3) Remove Preset: Press **【RESET】**, then press one of the number (0-9) to remove a preset that corresponds to the NUMBER.

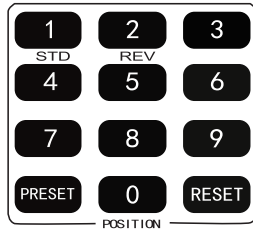

6.6 Dial-up On/Off Set

SW1

SW2

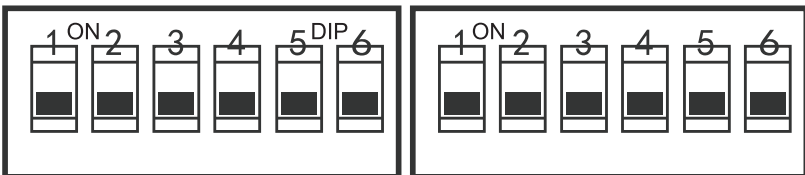

6.7 Dial-up SW1 (1,2,3,4,5,6,) : Buad Rate Set

SW1						
PTZ Add.	DIP-1	DIP-2	DIP-3	DIP-4	DIP-5	DIP-6
1	ON	OFF	OFF	OFF	OFF	OFF
2	OFF	ON	OFF	OFF	OFF	OFF
3	ON	ON	OFF	OFF	OFF	OFF
....						
63	ON	ON	ON	ON	ON	ON

6.8 Dial-up SW2 (1/2/3) : Set Protocol

SW2				
Protocol	DIP-1	DIP-2	Baud	DIP-3
VISCA	OFF	OFF	9600	OFF
PELCO-D	OFF	ON	38400	ON
PELCO-P	ON	OFF		

6.9 Dial 3 IR Transfer (IR PASS) , DIP-4 Reserve

IR Add	DIP-5	DIP-6	DIP-4
All	OFF	OFF	RESERVE
1	OFF	ON	
2	ON	OFF	
3	ON	ON	

6.10 RS-232 Interface Distribution

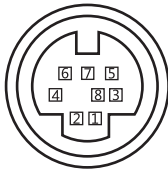

VISCA RS-232 IN

- | | |
|--------|-------|
| 1.N.C. | 1.CD |
| 2.N.C. | 2.RXD |
| 3.TXD | 3.TXD |
| 4.RXD | 4.DTR |
| 5.GND | 5.GND |
| 6.N.C. | 6.DSR |
| 7.N.C. | 7.RTS |
| 8.N.C. | 8.CTS |
| | 9.RI |

6.11 RS-485 Interface Distribution

PIN NUM	FUNCTION
A	DTR IN+ (connect to RS-485)
B	DSR IN-(connect to RS-485)

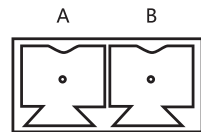

7. Installation Instructions

7.1 Surface Installation

Put the camera on the desk flatly, and make sure the camera is in a horizontal position. If you want to put the camera on an oblique surface, please make sure the angle of inclination is less than 15 degrees to ensure the camera pan and tilt work in normal operation.

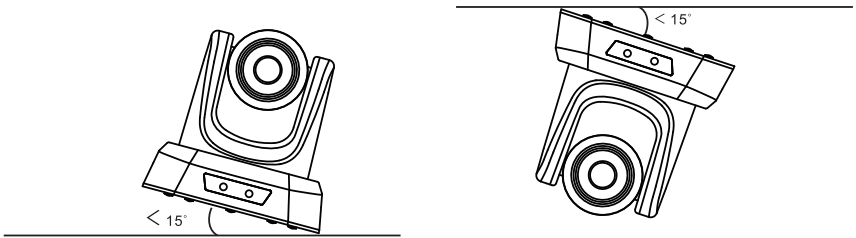

7.2 Ceiling Mount Installation

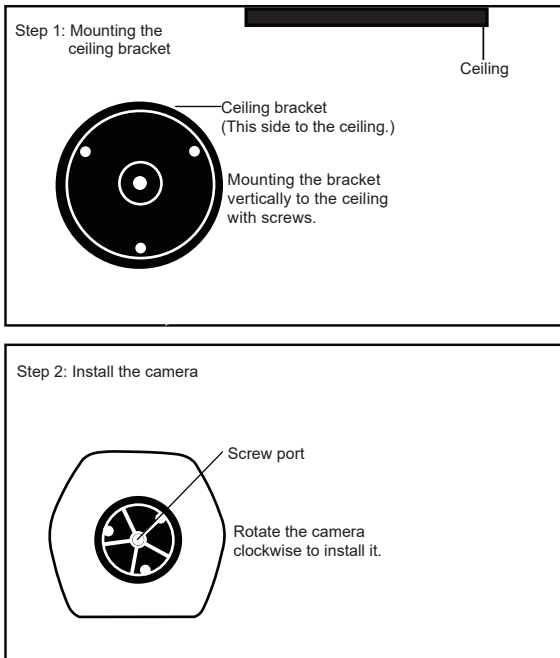

8. Trouble Shooting

Before requesting service to service engineer, please refer to the following methods to remove failures. If the failures still can't be solved, please contact us for assistance.

Q: The video of the camera cannot be displayed on the screen.

A: Please check the connection between power cable, video cable, camera and monitor, fix the connector on each end.

Q: It's unable to Pan, Tilt and Zoom camera.

A: Because the menu was displayed on monitor. Please re-operate after exiting the menu.

Q: Why the camera rotates for about 10 seconds after power on?

A: This is the normal self-test of the camera.

Q: Poor Image quality while using in church or other low-light conditions.

A: Press menu (ON/OFF) to adjust backlight effect to suit the church lighting properly.

Q: Remote control is not working or insensitive.

A: ①Not work, please replace batteries.

②Not sensitive: Choose the correct "IR select" number to correspond to the camera. Control the camera within 15m (49.2ft). Remove the obstacles. Aim at the sensor which is in front of the camera when controlling it.

Q: USB interface is not identifiable.

A: Please check if the USB cable and extension cable are well connected. If yes, change to another USB interface and try to connect again.

Q: It won't be controlled via RS-232/RS-485 when camera connect to PC.

A: Make sure it is a correct connection between the camera and PC. (Reference to RS-485 and RS-232 Pins distribution on page 10).

Q: Why no wall mount bracket?

A: Camera comes with ceiling mount, wall mount or tripod bracket need to buy separately.

Q: Does this camera has built-in mic?

A: No, this camera comes with no built-in mic.

Q: Can we control the camera only by the remote control?

A: You can control the camera by remote control, keyboard controller (joystick), and software.

9. Maintenance Services

All products purchased from our company are guaranteed to keep in good repair for 36 months. If there are any quality problems during the guarantee period, we will maintain them for free.

Under any of the following warranties, related maintenance costs will be collected:

1. Product was not normally used.
2. Fire, electric shock, outside object collapse or other natural disasters causing the equipment damaged.
3. Unauthorized repair, misuse, abuse or change.

Warranty Card

Thank you so much for choosing our products.

User's Info

Name: _____ Tel: _____

Email: _____ Post Code: _____

Address: _____

Product's Info

Product Name: _____

Factory Serial Number: _____

Fault Description

Attention

1. This card is considered as the protection to fix warranty, so please reserve it carefully. Please fill in truthfully.
2. Please indicate the model number, factory serial number and the detailed description of the fault information.



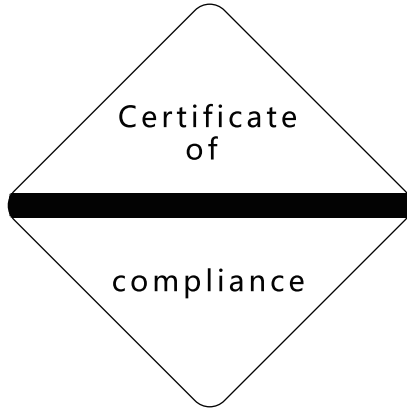



Make every meeting better and easier!